

THERMAL MASS FLOW METERS

S 415/S 418

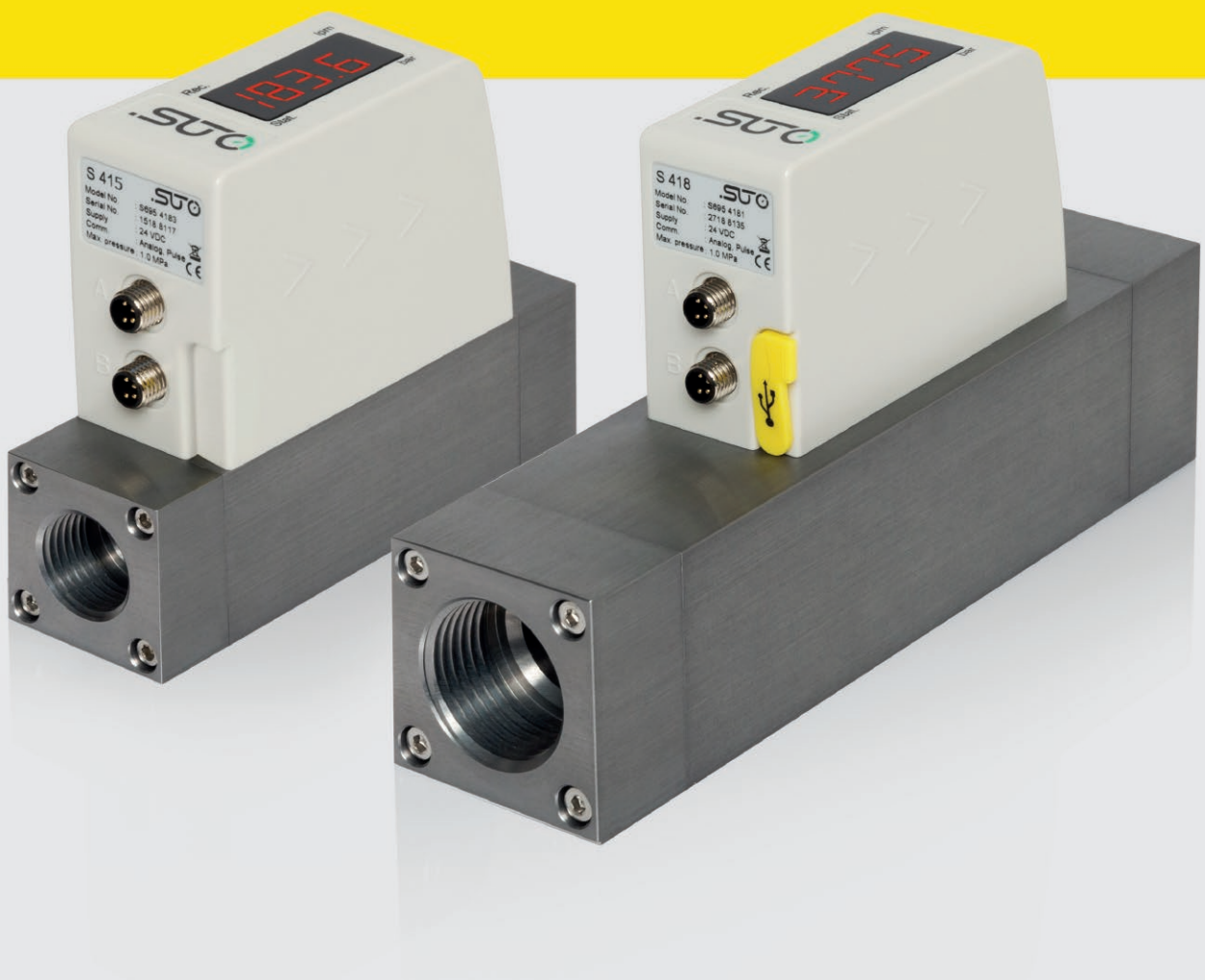

SMARTPHONE ANDROID APP
For remote configuration



Monitor your flow — optimize process efficiency



S 415/S 418 FEATURES



SMARTPHONE ANDROID APP

For remote configuration



POINT-OF-USE INSTALLATION

No straight pipe section required



COMPACT DESIGN

Can be installed anywhere



TOTAL FLOW

No bypass measurement



EASY PROCESS MONITORING

Effective and inexpensive recording



ACCURATE RESULTS

Integrated flow conditioner

The more accurate you can monitor gas flow, the more likely you will discover weak points in the process flow, thus ensuring continuity and profitability.

Asymmetric velocity profiles, swirl, and other factors caused by bends in pipes can lead quickly to inaccurate readings. And it is often not possible to place flow meters at hard-to-reach places.

The solution is our new generation of compact, easy-to-install, reliable and cost-effective flow and consumption meters: the S 415 and the S 418.

S 415/S 418 BENEFITS

- Convenient installation, great flexibility, can be installed anywhere
- Available as DN8, DN15, DN20 and DN25 (G female thread)
- Eco version S 415: Accuracy of 3% o.RDG, measuring volume 50: 1
- Pro version S 418: Accuracy of 1.5% o.RDG, measuring volume 100: 1
- Pro version S 418: Integrated data logger and pressure gauge option

S 415/S 418 DIMENSIONS

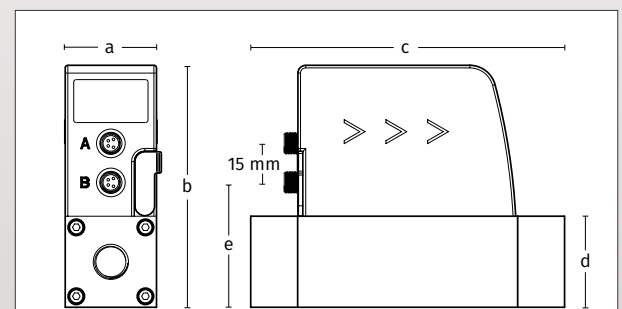

Dimensions in mm	a	b	c	d	e
DN8/DN15	35.0	93.0	120.4	35.0	48.0
DN20/DN25	48.0	106.0	178.0	48.0	61.0

S 415/S 418 TECHNICAL DATA

General Specifications		
Inner thread	DN8, DN15, DN20, DN25	
Process connection	G inner thread (ISO 228-1)	
Pressure range	0 ... 1.0 MPa	
Ambient / Transport temperature	0 ... +50°C / -30°C ... +70°C	
Medium conditions	0... +50°C / rH < 90% no condensation	
Power supply	18 ... 30 VDC / 120 mA	
Output signal	(A) Analogue 4 ... 20 mA, pulse (B) RS-485 (Modbus RTU) (C) Digital M-Bus	
LED display	4-Digit / S 415: Flow / S 418: Flow + Pressure (option)	
Material	Process connection: aluminium alloy Wetted parts: aluminium alloy Top casing: PC + ABS	
Classification	IP54	
Electrical connection	2 x M8, 4 poles	
Approvals	CE, RoHS	
Configuration	S 415 (Eco)	S 418 (Pro)
Turndown ratio	50:1	100:1
Accuracy (at 6 bar, 20°C, rH < 40%)	3% of reading	1.5% of reading
Measured gas	Air, N ₂	Non-corrosive gases, up to 2 calibrated gases
Response time (T90)	1 sec	0.1 sec
Interface	Wireless for Service App	Wireless for Service App, USB for logger readout
Data logger	None	Memory size: 8,000,000 samples Channels: up to 4 channels (Flow, Consumption, Temperature, Pressure) Sampling rate: 1 sec ... 1 h
Pressure sensor option	None	Range: 0 ... 1.0 MPa Accuracy: 1% F.S.
Calibrated Gas Types	S 415 (Eco)	S 418 (Pro)
The S 415 can be calibrated for Air or N ₂	A Air	A Air
	D N ₂	B CO ₂
The S 418 can be calibrated for up to two gases. Standard is Air.		C O ₂ (oil & grease free)
		D N ₂
		E N ₂ O
		F Ar
		G Natural gas
		H H ₂ (real gas calibration)
		I Other gas (specify)
		J He (real gas calibration)
		K C ₃ H ₈
	Z No gas	

Thread / Measuring Range	Standard Configuration			
Process connection	DN8	DN15	DN20	DN25
Measuring range (S) in l/min	250	1000	2000	3500
Low range (L) in l/min	50	200	400	700

Stated measuring ranges under following conditions:

- Standard flow in air
- Reference pressure: 1000 hPa
- Reference Temperature: +20°C

S 415/S 418 ORDERING



Visit our website or e-mail us:
www.suto-itec.com
sales@suto-itec.com

Please use the following tables to assist in placing your order with our sales staff.

S 415 Thermal Mass Flow Meter (Eco Version)		
Order No.	Code	Description
S695 415	S 415	S 415 mass flow meter G inner thread, 3% o. RDG, 24 VDC Gas types Air or N ₂ Measuring range (S)* 5 m cable with M8 connector and open ends included
Connection tread		
S695 415	0	DN8 G thread connection
S695 415	1	DN15 G thread connection
S695 415	2	DN20 G thread connection
S695 415	3	DN25 G thread connection
Output		
A1450	A	Analog 4... 20 mA, Pulse Output
A1451	B	Modbus RTU output
A1452	C	M-Bus output
Range		
	S	Standard range version
A1453	L	Low range version
Units		
	A	with SI units
A1458	B	with imperial units instead of SI units
Gas type		
A1007	A	Air
A1010	D	N ₂

Example: S 4150BSDA
 DN8, Modbus RTU, Standard range, imperial units, Air

S415/418 Accessories	
Order No.	Description
A554 3315	T-BOX for S 415/418 Modbus/M-Bus systems, including 2 m cable with M8 connector
A554 0109	Mains power supply 100-240 VAC / 24 VDC, 0.5 A, 2 m cable with M8 connector
A553 0137	Connection cable S 415/418 to S 551, 5 m
M599 7020	S4A data analysis software, for data logger S 418

*Both devices are delivered with the standard measuring range (S). If the low measuring range (L) is required, please provide this with your order.

S 418 Thermal Mass Flow Meter (Pro Version)		
Order No.	Code	Description
S695 418	S 418	S 418 mass flow meter with integrated data logger G inner thread, 1.5% o. RDG, 24 VDC Gas types A-K and B-Z Measuring range (S)* 5 m cable with M8 connector and open ends included
Connection thread + Pressure sensor option		
S695 418	0	DN8 G thread connection
S695 418	1	DN15 G thread connection
S695 418	2	DN20 G thread connection
S695 418	3	DN25 G thread connection
S695 418	5	DN8 G thread connection, Pressure sensor 10 barg 1% F.S
S695 418	6	DN15 G thread connection, Pressure sensor 10 barg 1% F.S
S695 418	7	DN20 G thread connection, Pressure sensor 10 barg 1% F.S
S695 418	8	DN25 G thread connection, Pressure sensor 10 barg 1% F.S
Output		
A1455	A	Analog 4... 20 mA, Pulse Output
A1456	B	Modbus RTU output
A1457	C	M-Bus output
Range		
	S	Standard range version
A1453	L	Low range version
Units		
	D	with SI units
A1459	E	with imperial units instead of SI units
Gas type		
A1007	A	Air
A1008	B	CO ₂
A1009	C	O ₂ (Oil- & grease-free cleaned)
A1010	D	N ₂
A1011	E	NO ₂
A1012	F	Argon
A1013	G	Natural Gas
A1014	H	H ₂ (Real gas calibration)
A1015	I	Other Gas (Please specify)
A1016	J	He (Real gas calibration)
A1017	K	C ₃ H ₈
	Z	No Second Gas

Example: S 4187BLDAZ
 DN20, pressure sensor, Modbus RTU, Low range, SI units, Air,
 No Second Gas